

Infilex™ GD

Multipurpose Data Gathering Panel

Model WY5110

General

Infilex GD (Infilex: named for “Infinity” and “Flexible”) Model WY5110 is a multipurpose terminal data transfer device designed to collect the data about various types of equipment inside the building, to monitor the equipment status, and to control the equipment operation.

Infilex GD can communicate with BAS (building automation system) main control unit (Yamatake’s savic-net™ series) through the transmission trunk line called NC-bus. By sending the operation status to the main control unit or by controlling the operation based on the commands sent from the main control unit, the integrated control of the entire building can be performed.

Infilex GD consists of a basic unit and connectable I/O modules (and a user interface module). The number and types of the modules can be flexibly changed corresponding to the total number of the management points.



Features

1) Compact design

The compact design allows free installation in a desired place.

2) I/O module configuration

Input and output types can be selected, and the number of points to be mounted can be increased or decreased corresponding to the application.

3) User interface module (Operator Panel)

Operator Panel (panel mount type / integral type) connected to Infilex GD allows you, sitting by the Infilex GD, to change the Infilex GD settings.

4) Autonomous distributed control

Even if a trouble occurs in the BAS, the backup operation is performed individually to distribute potential risks caused by malfunction of the system.

5) Installation

A quick-fit screwless terminal block is used for the communication terminal block of the I/O module, ensuring the labor saving of the wiring work. Additionally, a desired mounting method can be selected from two kinds of mounting methods, DIN rail mounting and screw mounting.

* Yamatake’s controller Infilex series: Infilex is named for “Infinity” and “Flexible.”

Safety Instructions

Please read instructions carefully and use the product as specified in this manual. Be sure to keep this manual nearby for ready reference.

Usage Restrictions

This product is targeted for general air conditioning. Do not use this product in a situation where human life may be affected. If this product is used in a clean room or a place where reliability or control accuracy is particularly required, please contact Yamatake's sales representatives. Yamatake Corporation will not bear any responsibility for the results produced by the operators.

WARNING



- DANGER: To prevent the risk of severe or fatal electrical shock, always disconnect power source and product power supply before performing any wiring.



- Do not disassemble the product. Equipment damage or electrical shock may occur.



- Use crimped terminal with insulation for electric wires connected to the screw terminals.



- Make sure all the wires are tightly connected to prevent heat generation or equipment damage.



- Do not detach the terminal cover except when connecting or disconnecting the wires. After connecting or disconnecting them, be sure to reattach the terminal cover. Confirm that the terminals and wires are not current-carrying when attaching or detaching the terminal cover.



- The strip length of insulated wires to be connected to the quick-fit screwless terminal block must be 8 mm. If the strip length is longer than 8 mm, the conductor will be exposed, causing electrical shock or short circuit between adjacent terminals. If it is shorter, the conductor will not contact the connector.

CAUTION



- Installation must be performed by qualified personnel in accordance with all applicable safety standards.



- Installation must be carried out according to the operating conditions specified in this manual to prevent equipment damages.



- Be sure to ground. Improper grounding may cause electrical shock or equipment damages.



- All wiring must comply with local codes of indoor wiring and electric installation rules.



- Do not plug in or out the I/O (input/output) modules with the product power turned on to prevent equipment damages.



- If more than the rated power supply voltage is applied, product replacement is required for safety.



- Do not peel off the label with  marked on.



- Install this product in a location out of reach of unauthorized people (e.g. inside of the control panel).



- Implement protection measures against lightning in consideration of the regional characteristics and building structure in order to minimize lightning damages.



- Select the rated surge absorber appropriate for the voltage, current, and capacity of the circuit to be used.



- After completing the wiring, be sure to peel off the protective sheet.



- Do not block the vent holes on the upper or lower part of the product to prevent equipment damages.



- Wiring installation must be carried out with cable binding bands so as not to hide the LED, Data Setter connector, ► mark, switch, battery holder, and tag.



- Before replacing the unit, make sure that the product power supply is disconnected.



- After mounting the product on DIN rail, make sure that the holding parts of all the modules are properly fixed with their whole parts lifted. The product may drop from the DIN rail and be damaged due to improper mounting.



- Do not incinerate this product for waste disposal (the housing produces toxic gas when incinerated). Do not recycle all or a part of this product, either.



- Dispose of the lithium battery in accordance with the local regulations.

Trademark information:

Inflex and savic-net are trademarks or registered trademarks of Yamatake Corporation in Japan or in other countries.

System Configuration

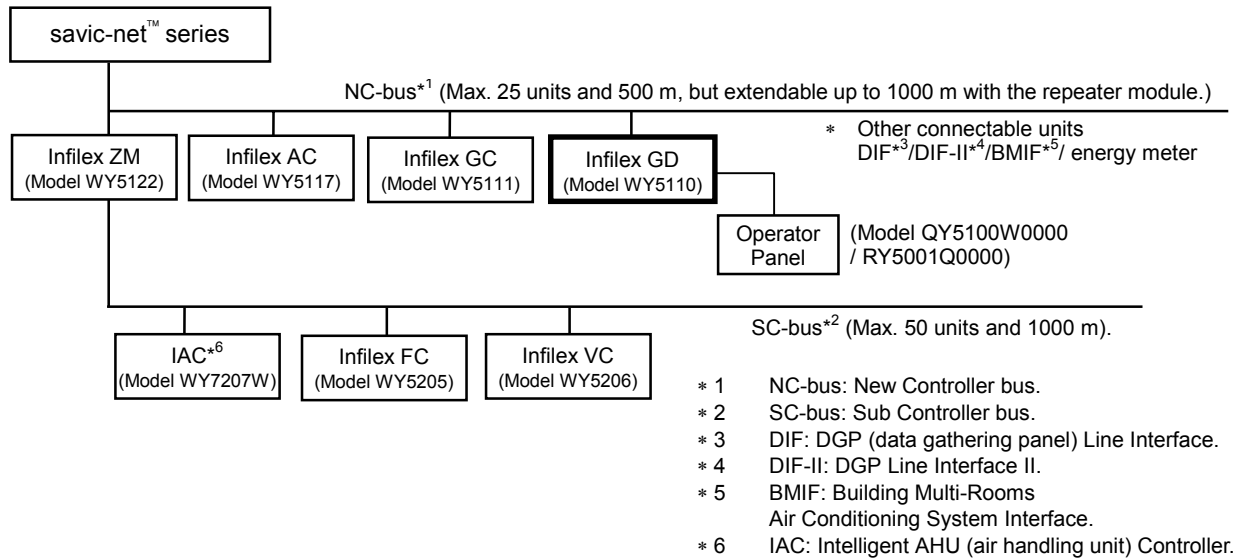

Figure 1. System configuration example

Specifications

Item		Specification		
Power supply		Rated voltage	24 V AC, 50 Hz / 60 Hz	
		Operating power voltage	20.4 V AC to 27.6 V AC	
		Power shutdown detection	19.2 V AC or less	
		Power consumption	40 VA	
Environmental conditions	Rated operating conditions	Ambient temperature	0 °C to 50 °C	
		Ambient humidity	10 %RH to 90 %RH (Non-condensing)	
		Vibration	Max. 3.2 m/s ² (0.33 G) at 10 Hz to 150 Hz	
	Transport and storage conditions	Ambient temperature	-20 °C to 60 °C	
		Ambient humidity	5 %RH to 95 %RH (Non-condensing)	
		Vibration for storage	Max. 3.2 m/s ² (0.33 G) at 10 Hz to 150 Hz	
LED indication	Operation	Power supply (POWER)	Green LED ON: Power ON Green LED OFF: Power OFF	
		Major failure (ERR1)	Red LED ON: Major failure or system restart Red LED OFF: Normal operation	
			Minor failure (ERR2)	Red LED ON: Minor failure or system restart Red LED OFF: Normal operation
		Communication		NC-bus
		Power failure backup	RAM*1, RTC*2	Lithium battery backup
			Data file	Nonvolatile memory backup
	Communication	NC-bus	Transmission system	Current transmission
Transmission speed			4800 bps	
Transmission distance			500 m	
Number of units connectable			25 units	
Weight		400 g		
Material (housing), color		Modified PPE, light gray		
Terminal block	Power supply, ground	M3 (7.62 mm interval between terminals)		
	NC-bus communication	Quick-fit screwless terminal block		

Notes:

- *1 Random Access Memory (RAM) is a memory in which data can be written and erased repeatedly. When the power is turned off, data will be erased. The memory is backed up for 48 hours by a lithium battery.
- *2 Real Time Clock (RTC) is backed up by a lithium battery to ensure accurate clocking while the power is OFF.

Wiring Specifications

• Basic unit

Note that pin terminals cannot be used.

Item	Wiring*	Wiring length	Condition
Power supply	JIS* ¹ IV 2.0 mm ² or JIS CVV 2.0 mm ² or greater	—	—
Grounding	JIS IV 2.0 mm ² or JIS CVV 2.0 mm ² or greater	—	Ground resistance: 100 Ω or lower
NC-bus	JCS* ² IPEV-S 0.9 mm ²	500 m	

Notes: *1 JIS: Japanese Industrial Standards

*2 JCS: Japanese Electric Wire and Cable Makers' Association (JCS).

• I/O module

Item	Wiring	Wiring length* ¹
Temperature input	JIS IV, JIS CVV, KPEV* ² 1.25 mm ²	100 m
Voltage/Current input	JIS IV, JIS CVV, KPEV 1.25 mm ²	100 m
Voltage/Current output	JIS IV, JIS CVV, KPEV 0.9 mm ² , 1.25mm ²	100 m
Modutrol motor output	JIS IV, JIS CVV, KPEV 1.25 mm ²	100 m
Digital input	JIS IV, JIS CVV, KPEV 0.5 mm ² , 0.75 mm ² , 0.9 mm ² , 1.25 mm ²	100 m
Relay output	JIS IV, JIS CVV, KPEV 1.25 mm ²	100 m
Rmote control relay output	JIS IV, JIS CVV, KPEV 1.25 mm ²	100 m

Notes: *1 The wiring length is the total of the wiring length to the relay terminal and the wiring length to the load from the relay terminal.

*2 KPEV is a wiring standard provided by Furukawa Electric Co., Ltd.

Since a quick-fit screwless terminal block is used for the I/O module, the wires can be connected only by stripping the sheath.

Sheath stripped length: 8 mm (Pin terminal cannot be used.)

Model Numbers

Model number		Description
WY5110	0000	Base model number
	C	24 V AC
	W	100 V AC to 240 V AC

Part Numbers

Part number	Description
83165861-001	Screw tab
83104567-001	DIN rail mounting bracket

Note: For mounting Inflex GD, either the screw tab (for screw mounting) or the DIN rail mounting bracket (for DIN rail mounting) is required. Be sure to separately order depending on your mounting type.

Input/Output and Terminal Arrangement

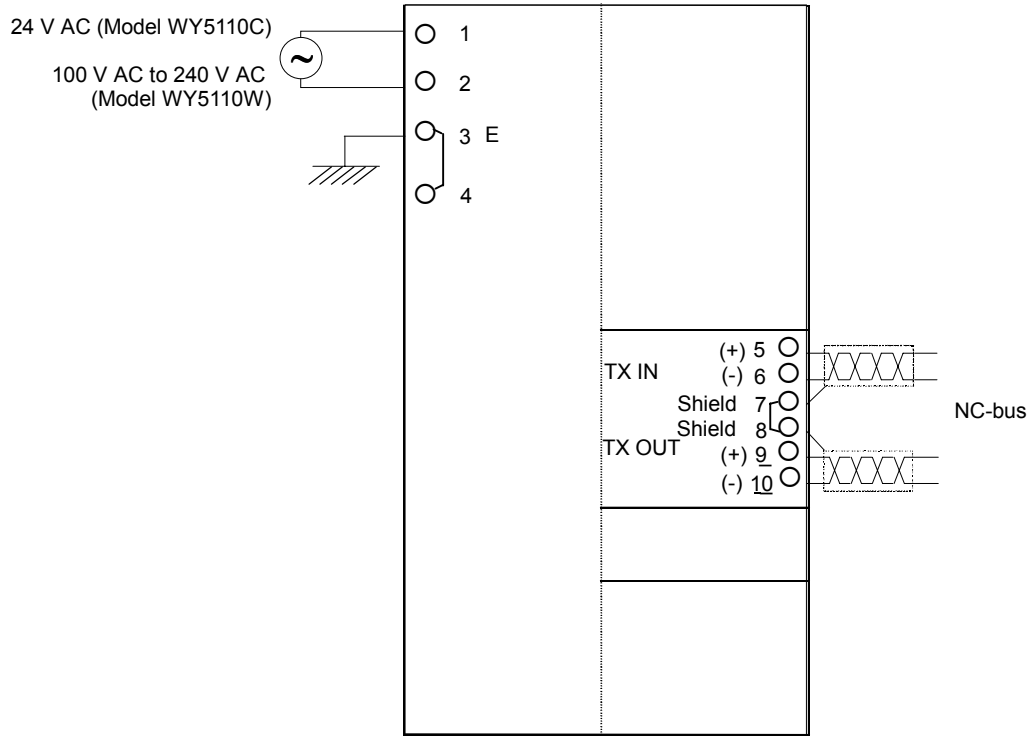

Figure 2. Input/output and terminal arrangement diagram

Dimensions

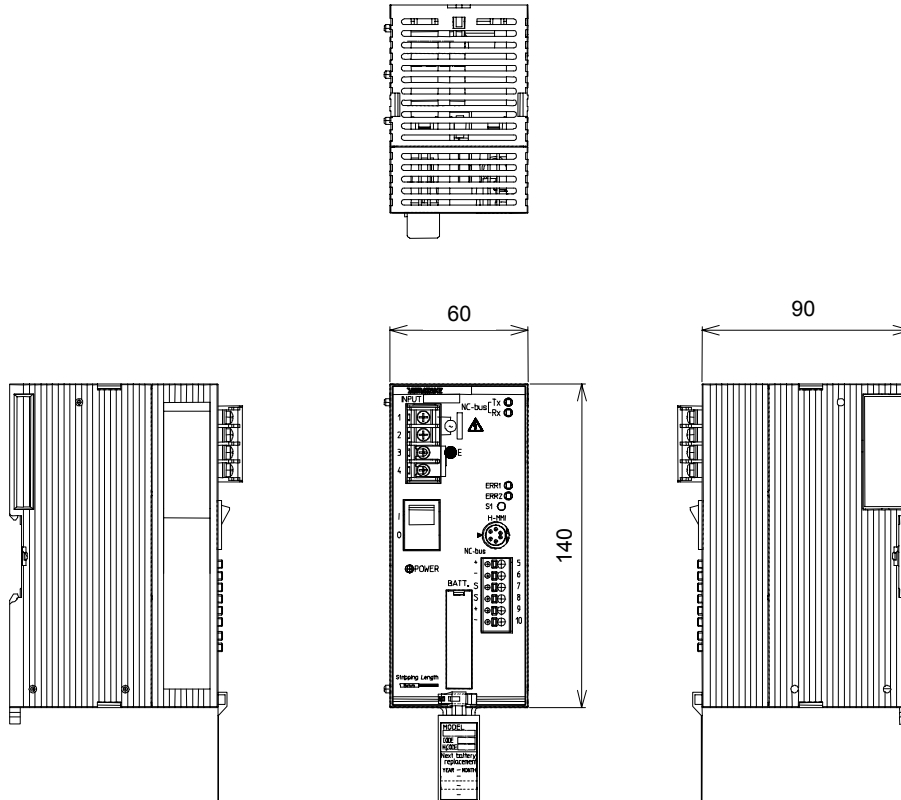

Figure 3. Dimensions (mm)

Parts Identification

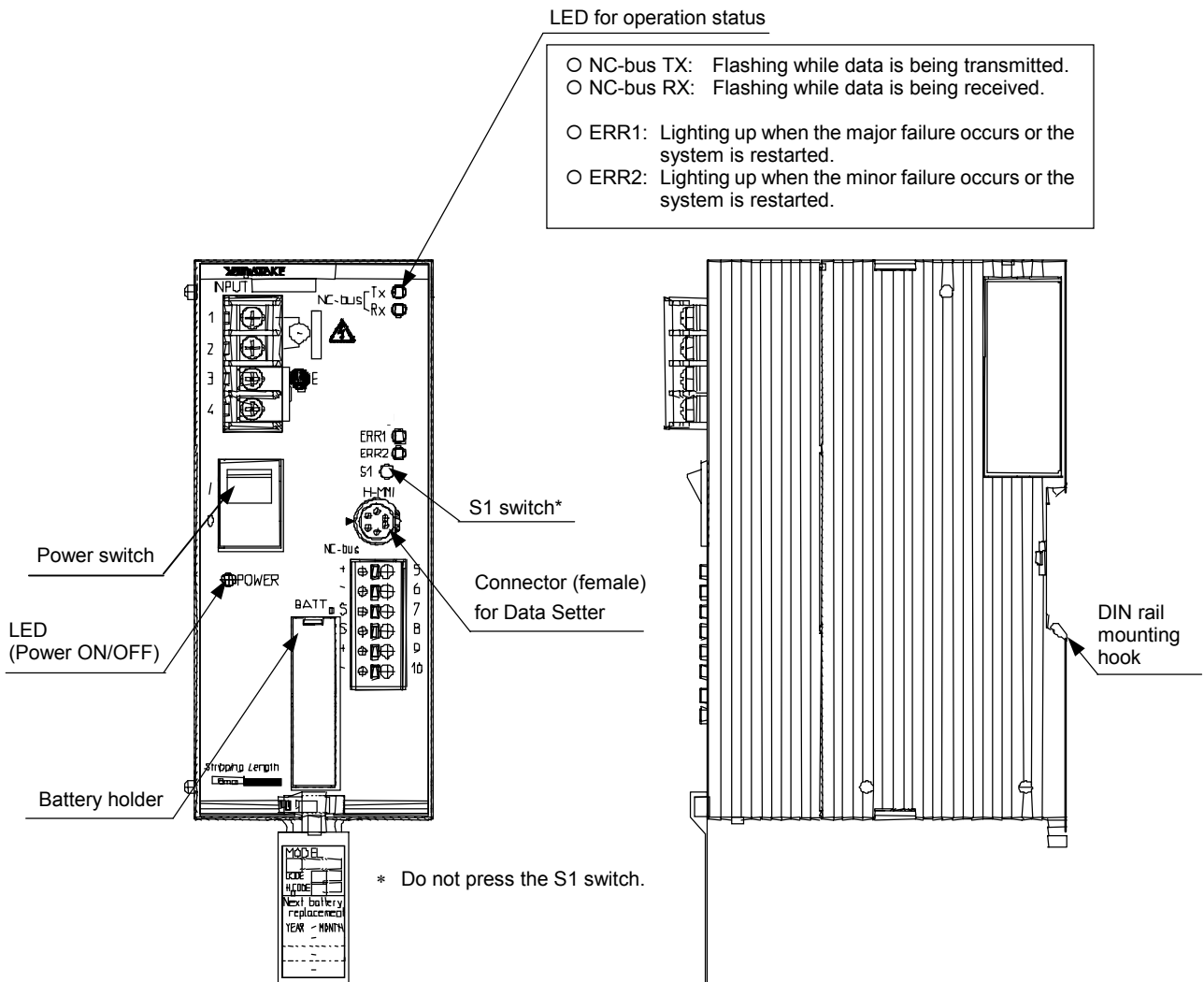

Figure 4. Parts Identification

Connections of Data Setter (H-MMI)

1) Connection of Data Setter Model QY5111A

No conversion cable is required. Directly insert the male connector of the Data Setter into the female connector provided on the Inflex GD main unit.

At this time, hold the male connector with the ◀ mark facing left and insert it as the mark points to the ▶ mark on the Inflex GD main unit.

2) Connection of Data Setter Model QY7211A

Convert the D-SUB connector to the mini DIN connector with the conversion cable (Part No. 83104995-001).

At this time, hold the male connector with the ◀ mark facing left and insert it as the mark points to the ▶ mark on the Inflex GD main unit.

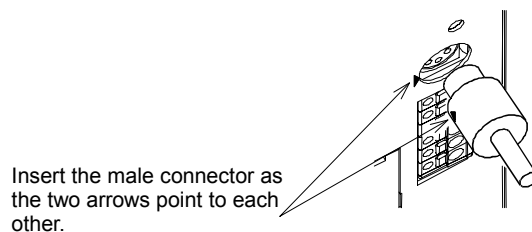

Figure 5. Data Setter connection

Mounting Dimensions

1. DIN rail mounting

Mount and fix Inflex GD on DIN rail so that it does not fall from the DIN rail.

Make sure that the holder parts of all the modules are properly fixed with their whole parts lifted.

Additionally, fasten the bilateral sides of Inflex GD with two DIN rail mounting brackets (Part No. 83104567-001, separate order is required).

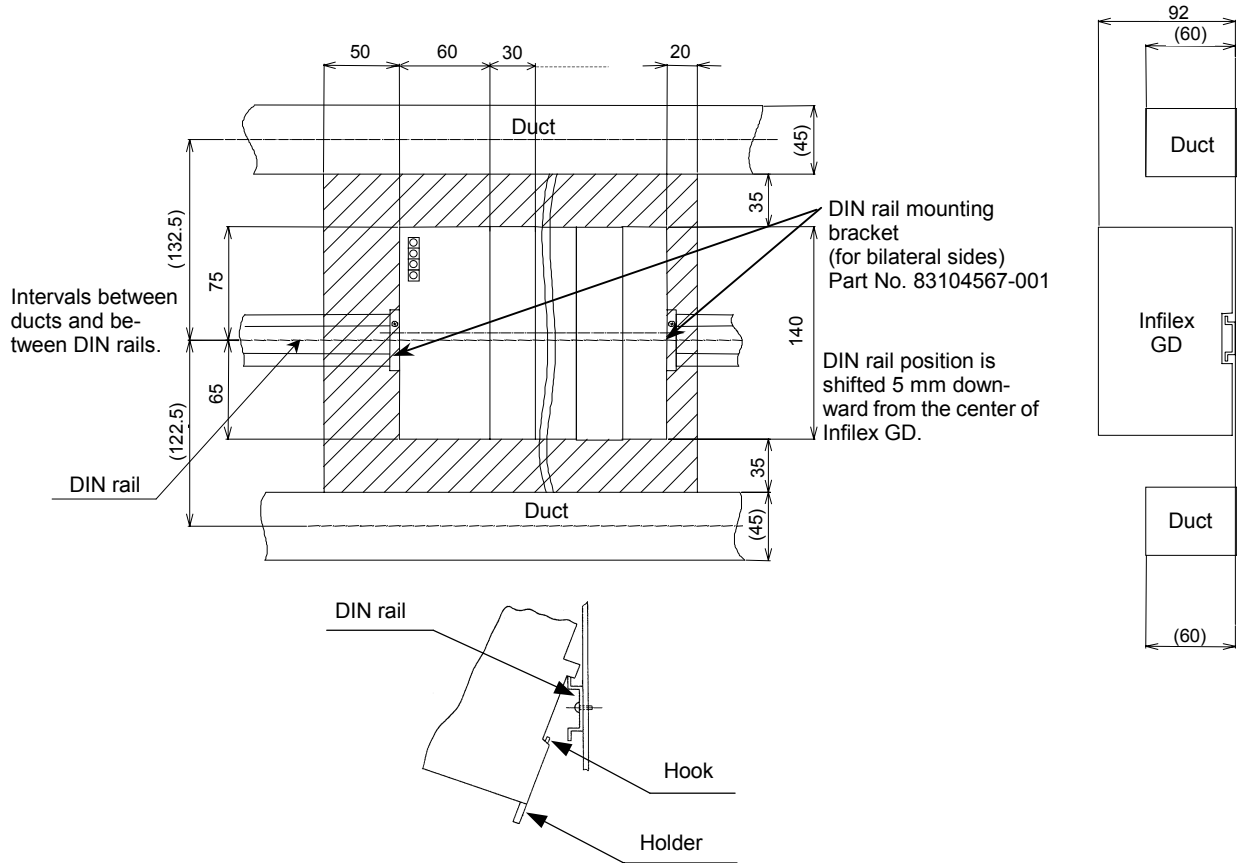

* Hatched area shows the maintenance space.

The width (horizontal dimension) may vary depending on the number of I/O modules and a user interface module (integral type Operator Panel or UT module) to be assembled. Their outside dimensions are the same.

One module (30 mm) × n (quantity) + Inflex GD main unit (60 mm)

Note: Panel mount type Operator Panel is not directly assembled with Inflex GD. To connect it to Inflex GD, a UT module is required.

For the dimensions of Operator Panel (panel mount type), please refer to Specifications/Instructions of Operator Panel (AB-6546).

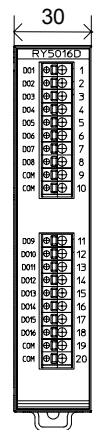

I/O module

Figure 6. DIN rail mounting (mm)

2. Direct screw-mounting

When Inflex GD is mounted with screws, screw tab (Part No. 83165861-001) is required. (Separate order is required.)

Mount and fix Inflex GD on the wall with two M4 × 8 screws.

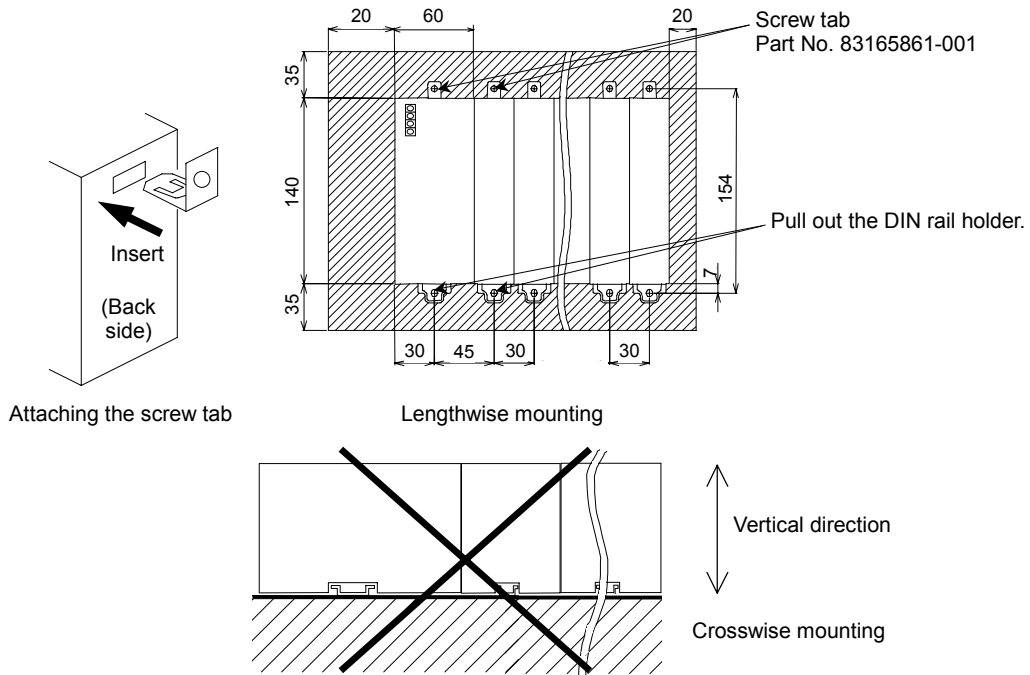

* Hatched area shows the maintenance space.

* Do not mount Inflex GD in the crosswise direction. Do not mount it with the surface plate facing upward or downward, either.

Figure 7. Direct screw-mounting]

Wiring

Wiring from power supply to terminal block

Attach the crimp terminals for the M3 screw terminal block to the wire ends, and connect them to the terminal block.

Wiring to I/O modules and NC-bus terminal block

Since quick-fit screwless terminal block is used for the I/O modules and the NC-bus terminal block, the procedure for wiring is specified as follows.

- 1) Strip the wire sheath 8 mm. (The gauge for the strip length is located at the front lower part of Inflex GD main unit. If the stripped part is longer than 8 mm, the conductor will be exposed, causing electrical shock or short circuit between adjacent terminals. If it is shorter, the conductor may not contact the connector.)
- 2) Make sure that no wire fiber is protruded from the stripped conductor.
- 3) Press the button on the terminal block deeply enough to insert the wire using a slotted screwdriver. (Maximum button-pressing force is 23 N {2.3 kgf}.)
- 4) Release the button, and gently pull out the wire to make sure that it is tightly fastened. Make sure that no wire fiber is protruded from the stripped conductor.

- * Install wiring properly so as not to hide the underlined parts shown in Fig. 8.
- * Make sure there is no slack in the wires from the cable ducts to Inflex GD.

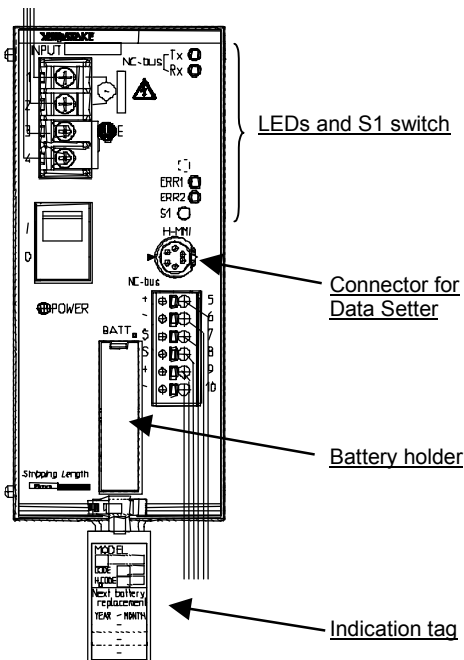

Figure 8. Connected wires in position

System indication label for the controller number

The indication tag has the system indication label on its back. Turn it over and fill in the controller number on the label.

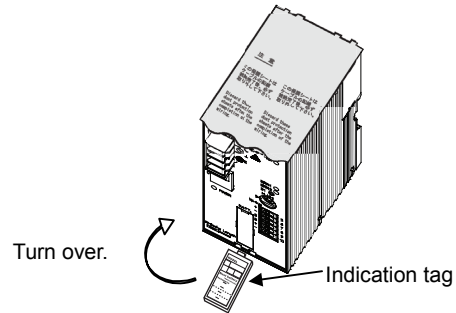

Figure 9. System indication label

Protective sheet

After wiring installation is completed, be sure to peel off the protective sheet before turning on the power.

- 1) Adhesive is applied to the sheet approximately 20 mm from the front edge. Peel off this area.
- 2) Tear off the sheet along the perforations.

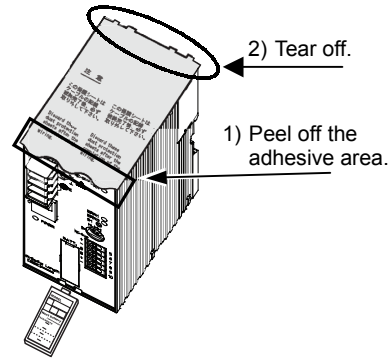

Figure 10. Protective sheet

Flat Tube Marker

Since Inflex GD adopts a quick-fit screwless terminal block, wire connection is carried out without crimp terminals. Therefore, if normal tube markers are used, they may come off when the wires are disconnected. To prevent this, use the following Flat Tube Marker. It is held on a wire by friction and thus does not come off easily.

Manufacturer name: Phoenix Contact
 Part name: Flat Tube Marker
 Part number: 5880029
 Model: TMC-3
 Applicable wire size: 0.4 mm² to 2 mm²
 Package unit: 200 m/roll

Maintenance

Replace the lithium battery for backup (Part No. 83104934-001) every 5 years.

⚠ CAUTION	
!	• Since the remaining battery capacity cannot be checked by measuring the terminal voltage, be sure to replace the battery every 5 years.
!	• Only authorized service personnel is allowed to replace the battery.
!	• Do not touch the power supply unit when replacing the battery.
!	• Replace the lithium battery every 5 years if the product is always in use (in ON state).
!	• Replace the lithium battery with the power ON.
!	• If the product has never or hardly been operated (in OFF state) for a year, replace the lithium battery before the product operation.

Battery replacement

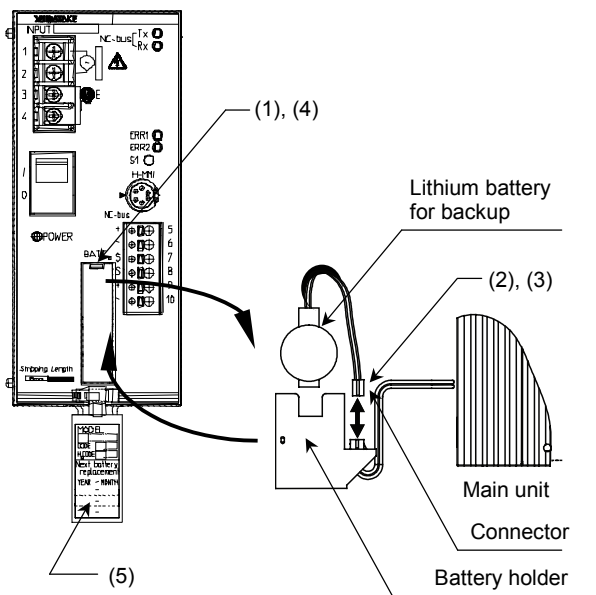

* Replace the battery with the Inflex GD in ON state.

Figure 11. Battery replacement

- (1) Pull out the battery holder using a slotted screwdriver.
- (2) Disconnect the connector and detach the lithium battery from the battery holder.
- (3) Place a new lithium battery in the battery holder and connect the connector to it.
- (4) Insert the battery holder into the main unit.
- (5) Fill in the date for next replacement (5 years after the replacement) on the tag using an oil-based pen.

Precautions for Use

- 1) Do not mount the product under the conditions of high temperature and humidity.
- 2) Do not drop the product.
- 3) For the wire replacement, be sure to shut down the power. (Disconnect the wiring between the power supply and the product power terminals.)
- 4) Before turning on the power, make sure that the wires are correctly connected.
- 5) Several tens of seconds are required for the product normal operation after the power is turned on. During this time, the red LED "ERR1" (major failure) on the front lights up indicating major failure temporarily, but this does not indicate an error.
- 6) Do not connect wires to vacant terminals.
- 7) Leave at least 35 mm clearance between the top/bottom surface of the product and other devices.
- 8) Peel off the protective sheet on the top surface of the product before turning ON the power. (See Figs. 10 and 12.)

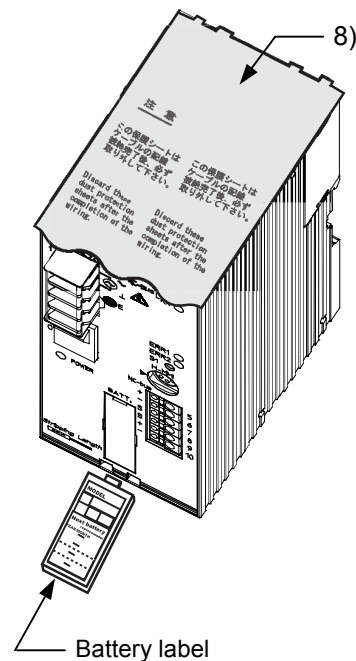

Figure 12. Battery label and protective sheet



Specifications are subject to change without notice.

Yamatake Corporation
Building Systems Company

<http://www.yamatake.com>