

ACTIVAL™

Motorized Two-Way Valve with Flanged Connection Model VY51X2J (JIS 20K-FCD450)

General

ACTIVAL Model VY51X2J is a series of motorized two-way valves with flanged connections. The valve and actuator are integrated in a single unit.

The valve body can be used for the control of chilled/hot water or hot water (in high temperature), and the body rating corresponds to JIS 20K (JIS: Japanese Industrial Standards).

The actuator has a reversible synchronous motor, which operates at a low voltage of 24 V AC.

5 kinds of control signals are available to operate the ACTIVAL. The built-in feedback potentiometer provides proportional control in combination with a proportionally controlled electronic controller. The nominal resistance 135 Ω input provides proportional control in combination with a proportional electric controller. 4-20 mA DC and 2-10 V DC inputs provide proportional control in combination with a direct digital controller (DDC).



Features

- Compact and lightweight.
- Valve and actuator integrated in a single unit.
- A variety of control signals available:
 - Nominal 135 Ω feedback potentiometer
 - Nominal 135 Ω resistance input
 - 4-20 mA DC input
 - 2-10 V DC input
- Valve with high differential pressure, large Cv values, high rangeability and low leakage.
- Durable design.
- Low power consumption.
- Equal percentage flow characteristics.
- 2-10 V DC output (for position feedback) available with 4-20 mA DC input type and 2-10 V DC input type.



















Safety Instructions

Please read instructions carefully and use the product as specified in this manual. Be sure to keep this manual nearby for ready reference.

Usage Restrictions

This product is targeted for general air conditioning. Do not use this product in a situation where human life may be affected. If this product is used in a clean room or a place where reliability or control accuracy is particularly required, please contact Yamatake's sales representatives. Yamatake Corporation will not bear any responsibility for the results produced by the operators.

CAUTION

-  • Installation must be performed by qualified personnel in accordance with all applicable safety standards.
-  • This product must be operated within its operating ranges specified in this manual. Failure to comply will cause equipment damages.
-  • Installation must be carried out under the operating conditions specified in this manual to prevent equipment damages.
-  • For storage, do not stack too many container boxes in which products are packed.
-  • Do not put heavy load on the actuator.
-  • Do not leave the controlled fluid frozen. Equipment damages and leakage may occur.
-  • Make sure the flow direction and install the product in the direction and position specified in this manual. Excessively tight connection of piping and improper installation position may cause equipment damages.
-  • Flush the piping so that no foreign substance remains. Attach a strainer at upstream side of the piping to prevent equipment damages.
-  • After the piping installation, make sure no fluid leaks from the connecting parts.
-  • Do not install the product in a location adjacent to a steam coil or a hot-water coil. High temperature radiation may result in an actuator malfunction.
-  • Avoid instrumentation that keeps equipment operating cycle excessively frequent so as not to shorten the equipment operating life.
-  • When this product is used with a controller of another manufacturer, contact Yamatake's sales representatives.
-  • All wiring must comply with local codes of indoor wiring and electric installation rules.
-  • Disconnect the power supply before performing any wiring to prevent electrical shock or equipment damages.
-  • Use crimp terminals with insulation for electric wires.
-  • Make sure all the wires are tightly connected to prevent heat generation and equipment damages.
-  • Do not disassemble the product at any time except when removing the cover to wire or replacing a part to prevent equipment damages.
-  • Do not incinerate this product for waste disposal. Do not recycle all or a part of this product, either.
-  • Dispose of this product as industrial waste in accordance with the local regulations.

Trademark information:

ACTIVAL, Inflex, Neostat are trademarks or registered trademarks of Yamatake Corporation in Japan or other countries.

Specifications

Valve

Item	Specification		
Model	Two-way valve with flanged connection		
Body pressure rating	JIS 20K (Max. pressure 1.96 MPa)		
Size, Cv Max. pressure drop	Nominal size (in inch)	Cv	Max. pressure drop (close-off ratings)
	DN15 (1/2)	1.0	980 kPa
	DN15 (1/2)	2.5	980 kPa
	DN15 (1/2)	6.0	980 kPa
	DN25 (1)	10	980 kPa
	DN25 (1)	16	980 kPa
	DN40 (1 1/2)	25	980 kPa
	DN40 (1 1/2)	40	980 kPa
	DN50 (2)	65	980 kPa
	DN65 (2 1/2)	95	980 kPa
	DN80 (3)	125	686 kPa
Materials	Body: Ductile cast iron (JIS FCD450) Plug, stem: Stainless steel (equivalent to JIS SCS) Seat ring: Heat-resistant PTFE Gland packing: Inorganic fiber Gasket: Non-asbestos joint sheet		
Piping connections	JIS 20K flanged connection: Large raised face (RF)		
Allowable fluid temperature	0 °C to 175 °C		
Flow characteristics	Equal percentage		
Rangeability	50 : 1		
Seat leakage	0.01 % or less of rated Cv value (0.0006 Cv or less for DN15 model)		
Paint of body	Gray (equivalent to Munsell 5B 4/1)		
Applicable fluids	Chilled/hot water or hot water (in high temperature)		
Installation orientation	Installable in any position ranging from upright (with the mounted actuator vertically above the valve) to sideways		
Installed actuator	Integrated with the valve		

Actuator

Item	Specification		
Power supply	24 V AC \pm 15 % 50 Hz/60 Hz		
Applicable valve size	DN15 to DN80 of standard torque type		
Power consumption	Nominal 135 Ω feedback potentiometer type: 7 VA Other types (nominal 135 Ω resistance input, 4 mA DC to 20 mA DC input and 2 V DC to 10 V DC input): 8 VA		
Timing	63 \pm 5 sec. (50 Hz) / 53 \pm 5 sec. (60 Hz)		
Control signal	Nominal 135 Ω feedback potentiometer <div style="display: flex; align-items: center;"> <div style="border-left: 1px solid black; border-right: 1px solid black; padding: 0 5px;">Feedback potentiometer</div> <div style="margin-left: 10px;">Total resistance: Nominal 135 Ω Max. applied voltage: 5 V DC</div> </div> Nominal 135 Ω resistance input 4 mA DC to 20 mA DC input (input impedance: 100 Ω) 2 V DC to 10 V DC input (input impedance: 150 k Ω or higher)		
Analog output (only with 4 -20 mA DC and 2-10 V DC inputs)	Range: 2 V DC (0 %) to 10 V DC (100 %) Max. load: 10 k Ω or higher (Max. 1 mA)		
Environmental conditions		Rated operating conditions	Transport storage conditions
	Ambient Temperature	-20 $^{\circ}$ C to 50 $^{\circ}$ C* (Fluid temperature 0 $^{\circ}$ C to 150 $^{\circ}$ C)	-20 $^{\circ}$ C to 70 $^{\circ}$ C*
		-20 $^{\circ}$ C to 40 $^{\circ}$ C* (Fluid temperature 150 $^{\circ}$ C to 175 $^{\circ}$ C)	
	Humidity	5 %RH to 95 %RH	5 %RH to 95%RH
	Vibration	4.9 m/s ² (10 Hz to 150 Hz)	19.6 m/s ² (10 Hz to 150 Hz)
(The actuator shall be packed during transport.) *Note: Do not allow the fluid to freeze.			
Materials	Case: Aluminum alloy casting Cover: Plastic (polycarbonate resin) (color: gray) Yoke: Steel plate		
Surface finishing	Case: None Yoke: Electro-galvanizing (bright chromate finish)		
Installation locations	Indoor Outdoor (keep away from direct sunlight.)		
Installation orientation	Installable in any position ranging from upright to sideways. (If being installed outdoors, it must be installed in upright position.)		
Valve position indication	Pointer located at the bottom of the actuator shows the position by pointing at the value of the scale (0: close to 100: open) on front, rear, and bottom sides.		
Manual operation	Disconnect from the power supply. Using a wrench, rotate the rectangular part (joint) at the connection between the valve and the actuator. Refer to the section "Manually Opening/Closing Valve."		
Wiring	Two knockout holes (ϕ 22 mm, for wiring port) are located on bilateral sides. Cut out the required one and connect the wiring to the terminal block with screws (M3.5).		
Enclosure rating	Splash-proof (equivalent to IEC (International Electrotechnical Commission) IP54)		
Insulation	Between terminal and cabinet: 5 M Ω or higher at 500 V DC		
Dielectric strength	Between terminal and cabinet: 500 V AC/min with 5 mA or less leakage current		
Position for shipment	Fully open		

Note: For weight of the ACTIVAL, refer to the table shown in the section "Dimensions".

Option

Item	Specification
Seal connector (Part No. 83104346-003)	Diameter of wire (mm): $\phi 7$ to $\phi 9$ (Seal connector is necessary for waterproof protection.)
Auxiliary switches (Part No. 83161792-001)	Number of auxiliary switches: Two Maximum applied voltage/current: 30 V DC, 3 A DC Switch actuating position: Adjustable between 0 % (fully closed) and 50 % for SW1 Adjustable between 50 % and 100% (fully open) for SW2
Auxiliary potentiometer (Part No. 83161793-001)	Number of auxiliary potentiometer: One Overall resistance: Nominal 1 k Ω Actuating position: 0 % (fully closed) to 100 % (fully open) Max. applied voltage: 5 V DC Note that ACTIVAL is not connectable to Modutrol Motor Model M904E with the auxiliary potentiometer.

Note: Either of an auxiliary switch or an auxiliary potentiometer can be added, but not both.

Selection Guide

Model VY51X2J00XX

The following model numbers are applicable to the ACTIVAL Model VY51X2J (JIS 20K) series.

A model number label is attached to the yoke. The control signal type is indicated on the actuator label and the wiring diagram label as follows.

- Nominal 135 Ω feedback potentiometer:

F.B. Pot

- Nominal 135 Ω resistance input:

135 Ω

- 4 mA DC to 20 mA DC input :

4-20 mA

- 2 V DC to 10 V DC input:

2-10 V

Base model number	Actuator/ Valve		Actuator		Valve	Description
	Control signal	Rating/ Material	Type	—	Valve size/Cv	
VY51						Flanged motorized two-way valve
	1					Nominal 135 Ω feedback potentiometer
	2					Nominal 135 Ω resistance input
	3					4 mA DC to 20 mA DC input with 2 V DC to 10 V DC output
	4					2 V DC to 10 V DC input with 2 V DC to 10 V DC output
		2				JIS 20K / JIS FCD450
			J			Splash-proof Standard torque type Actuator with terminal block (valve sizes: DN15 to DN80)
				00		—
					11	DN15 / 1.0 in Cv value
					12	DN15 / 2.5 in Cv value
					13	DN15 / 6.0 in Cv value
					21	DN25 / 10 in Cv value
					22	DN25 / 16 in Cv value
					41	DN40 / 25 in Cv value
					42	DN40 / 40 in Cv value
					51	DN50 / 65 in Cv value
					61	DN65 / 95 in Cv value
					81	DN80 / 125 in Cv value

Dimensions

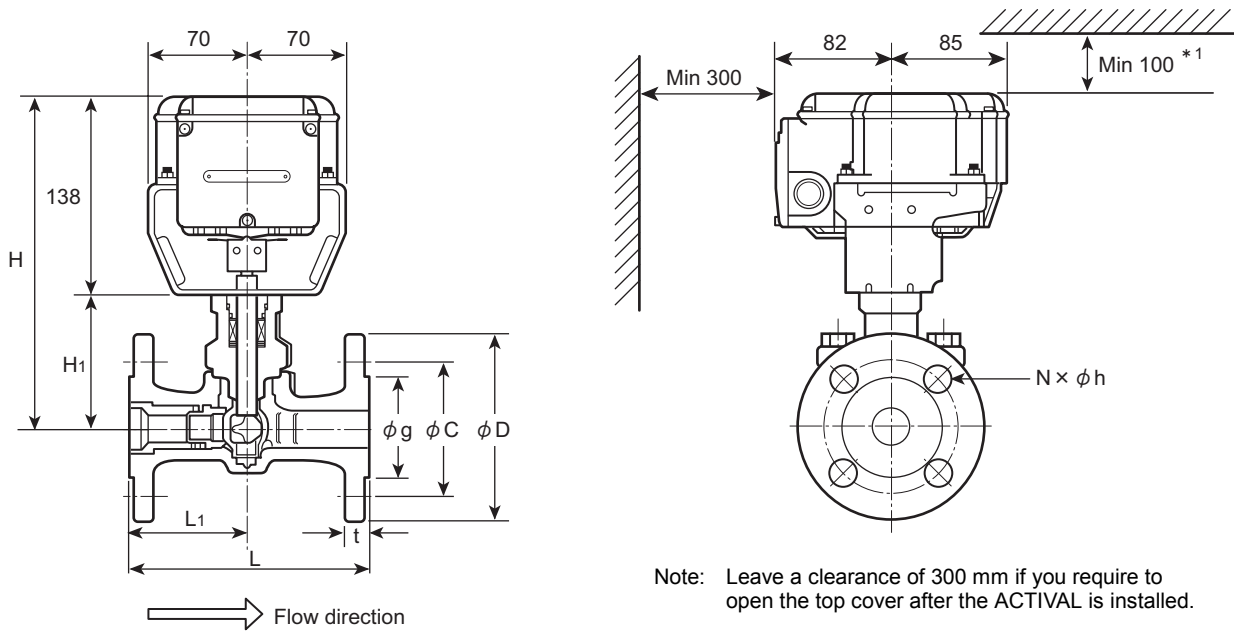

Figure 1. Dimensions (mm): Valve body (JIS FCD450)

Nominal size (DN)	L (mm)	L1 (mm)	H (mm)	H1 (mm)	ϕD (mm)	ϕC (mm)	ϕg (mm)	t (mm)	ϕh (mm)	N	Weight (kg)
15	140	70	214	75	95	70	51	14	15	4	5.4
25	165	82.5	229	90	125	90	67	16	19	4	7.8
40	190	95	242	103	140	105	81	18	19	4	10.6
50	216	108	246	107	155	120	96	18	19	8	12.8
65	241	120.5	267	129	175	140	116	20	19	8	19
80	283	141.5	268	130	200	160	132	22	23	8	23.5

Parts Identification

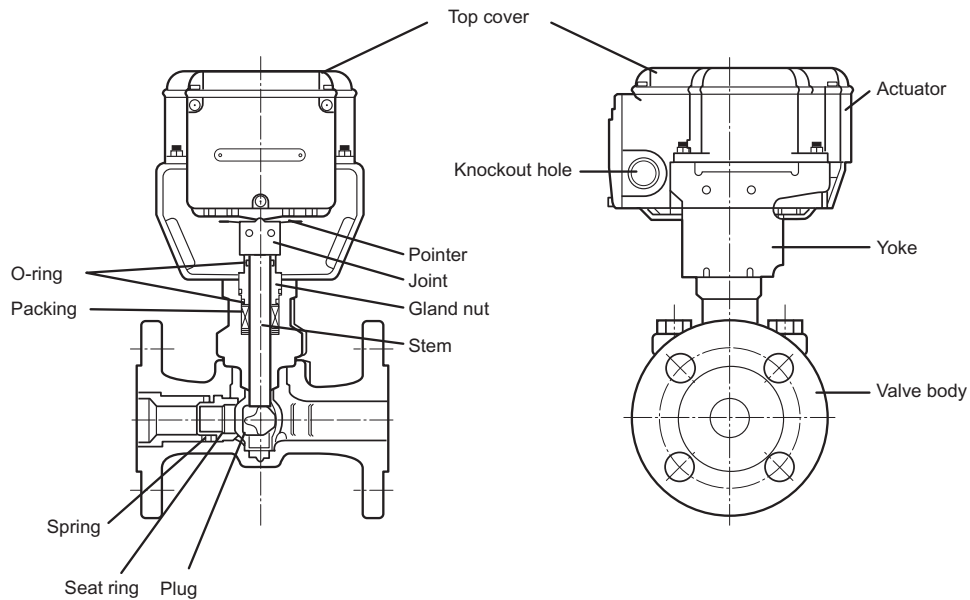

Figure 2. Parts identification

Precautions for Installation

Environment

⚠ CAUTION	
!	• Avoid using the ACTIVAL in an atmosphere containing oxidizing or explosive gas since it may corrode the actuator, the valve or their components.
!	• The cover might be corroded by some chemical and organic solvent. Do not expose the ACTIVAL to such substances.
!	• The actuator may malfunction if being placed near by hot objects. Do not install it near by steam or hot water coils.

Piping

- 1) Do not mount Model VY51X2J ACTIVAL on a pipe where water hammer occurs, or where solid objects may accumulate.
- 2) Install the ACTIVAL in a position allowing easy access for maintenance and inspection. Fig. 1 shows the minimum clearance for maintenance and inspection. When installing the ACTIVAL in a ceiling space, place a drain pan under the valve.
- 3) Install a bypass pipe and gate valves on the inflow, outflow and bypass sides. Also, install a strainer on the inflow side. When the ACTIVAL is used in steam applications, a strainer with 80 or more meshes is recommended.

- 4) Do not apply heat insulation to the actuator and the yoke. Apply heat insulation only to the area boxed with dotted lines shown in Fig. 3 if necessary.
- 5) Before the installation, check the model number on the label attached to the yoke. The process fluid should flow in the direction indicated by the arrow marked on the valve body.
- 6) The actuator can be mounted in any position from upright to sideways. The ACTIVAL should be installed with its actuator vertically positioned above the valve body. (See Fig. 4.) However, the ACTIVAL must be installed always in upright position outdoors.

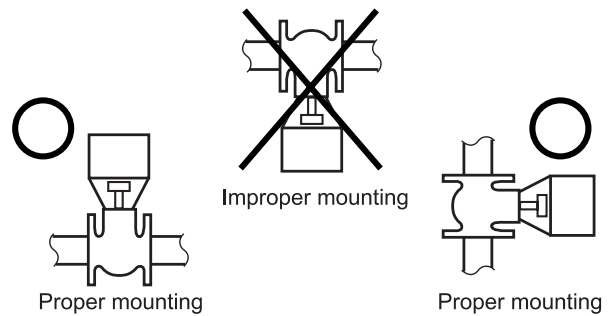

Figure 4. Actuator mounting position

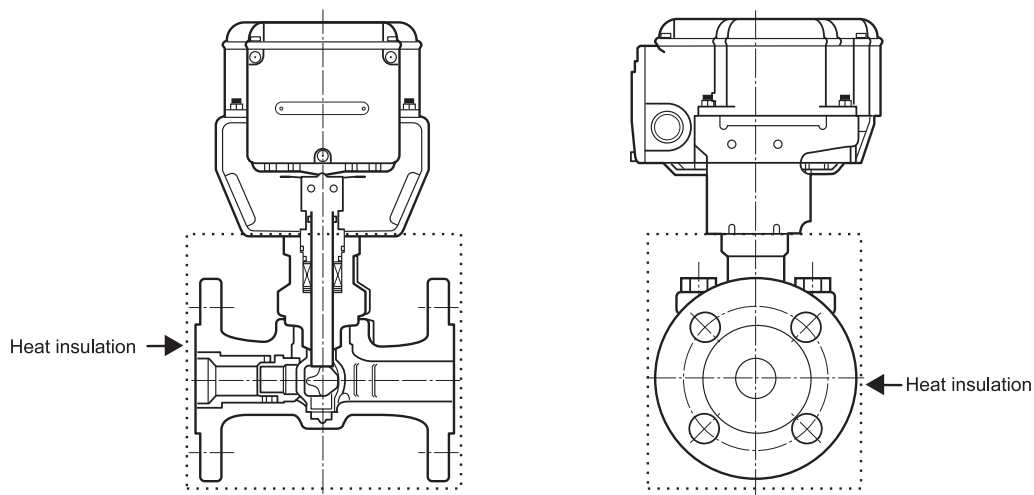





Figure 3. Area where heat insulation can be applied

Actuator

 CAUTION	
	<ul style="list-style-type: none"> Although the ACTIVAL can be used in high humidity environments (max. 95 % RH), do not immerse the actuator in water.
	<ul style="list-style-type: none"> Although the ACTIVAL can be used outdoors, be sure not to expose the actuator to direct sunlight.

The ACTIVAL features a single unit construction with the actuator and valve combined together. Do not separate.

Position for Shipment

The actuator shaft is positioned at 100% (in fully open position) for shipment. The shaft is completely turned counterclockwise, and the pointer points at "100". (See Fig. 5)

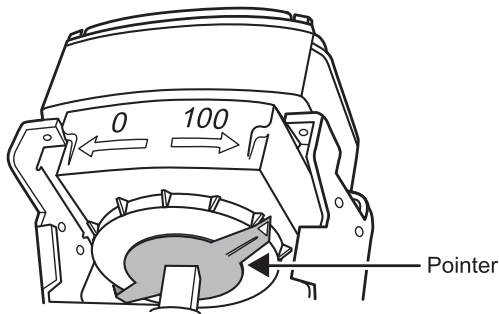

Figure 5. Pointer position for shipment

Changing the Actuator Connection Position

- 1) Change the actuator mounting position only when the actuator is in fully open position.
- 2) Remove the screws connecting the actuator and the yoke. Lift the actuator and detach it from the yoke. (Make sure that the groove at the top of the valve stem is parallel (in fully open position) to the piping.) <Step 1 in Fig. 6>
- 3) Remove the screws connecting the yoke and the valve body. <Step 2 in Fig. 6>
- 4) Change the direction of the yoke to the desired direction. The actuator can be horizontally rotated every 90° to fit into the valve mounting position (0°/90°/180°/270° from the factory preset position). <Step 3 in Fig. 6>
- 5) A thermal insulation sheet is inserted between the yoke and the valve. If the mounting position is changed, reinsert the thermal insulation sheet to fit into position (1 sheet between valve body and yoke).
- 6) Before fixing the yoke to the valve with screws, check that the actuator engages correctly with the stem. (Check that the actuator pointer is in fully open position.)
- 7) Mount the actuator, with its direction changed, to the yoke. <Step 4 in Fig. 6>

IMPORTANT:
Do not change the combination of valve body, yoke and actuator.

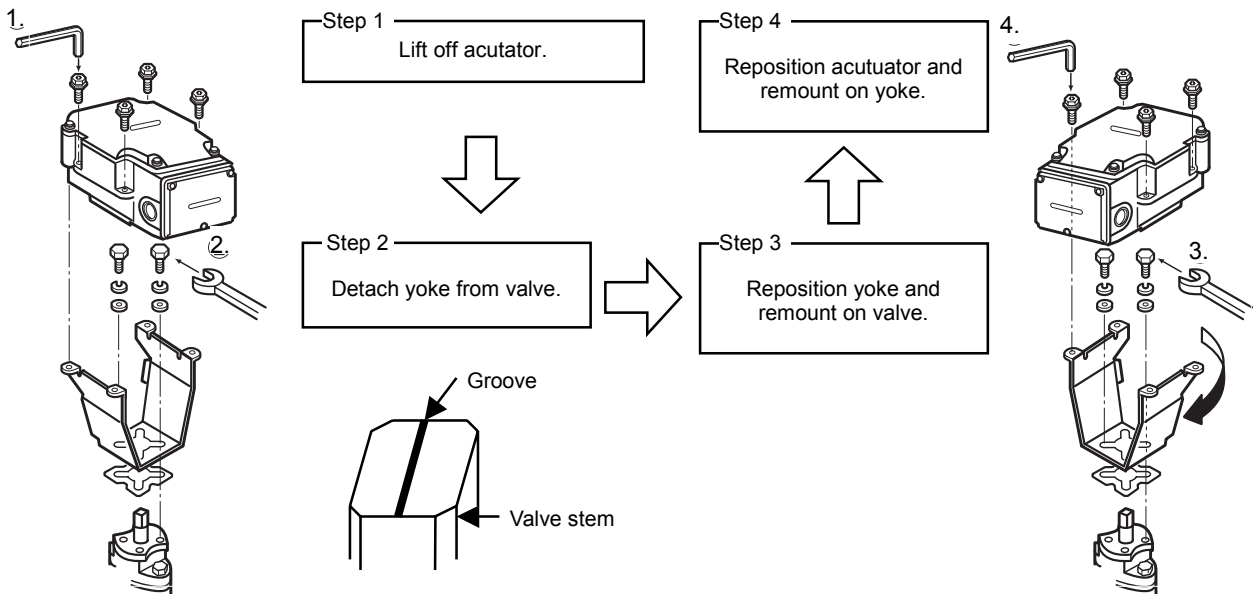





Figure 6. Changing the actuator mounting position

Manually Opening/Closing Valve

 CAUTION	
	<ul style="list-style-type: none"> To manually open or close the valve, be sure to disconnect the ACTIVAL from the power supply (24 V AC). If the valve is manually opened or closed with the power applied, the actuator may be damaged.
	<ul style="list-style-type: none"> Never rotate the joint out of “0” to “100” range of the scale.

Before manually opening or closing the ACTIVAL, make sure it is disconnected from the power supply.

As shown in Fig. 7, hold the joint with a tool such as a hexagonal wrench, and turn the joint slowly toward the position to set up.

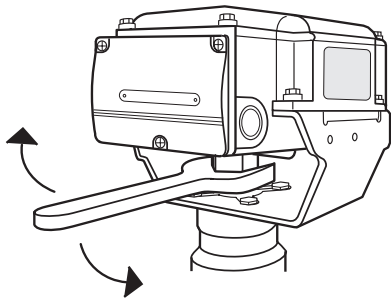











Figure 7. Manual open/close operation

Auxiliary Switch / Auxiliary Potentiometer (Optional)

 CAUTION	
	<ul style="list-style-type: none"> The auxiliary switch and the auxiliary potentiometer are installed on site. (See Fig. 15.) Refer to the instructions attached to them.
	<ul style="list-style-type: none"> Do not open the top cover except when adjusting the auxiliary switch or auxiliary potentiometer.
	<ul style="list-style-type: none"> Do not put a load on the cover.

Wiring

 CAUTION	
	<ul style="list-style-type: none"> Disconnect power supply before performing any wiring.
	<ul style="list-style-type: none"> This product is designed for 24 V AC power supply voltage. Do not apply mains power.
	<ul style="list-style-type: none"> For correct wiring of 4-20 mA DC input and 2-10 V DC input, refer to Figs. 10 to 13 and make sure the polarity of power supply and 2-10 V DC output. Incorrect wiring may result in PCB (printed circuit board) burnout.
	<ul style="list-style-type: none"> To prevent equipment damage, cover the actuator except during wiring work.

Wiring precautions

- Do not apply 24 V AC to the terminals 4, 5 and 6. (Max. applicable voltage: 5 V DC)
- To lead the wires into the actuator, cut out a knockout hole for a wiring port. There are two knockout holes on the bilateral sides of the actuator terminal block: one $\phi 22$ mm knockout hole on each side. Select a knockout hole according to the conduit mounting direction and cut it out by lightly knocking with a screwdriver. (Refer to Fig. 8)

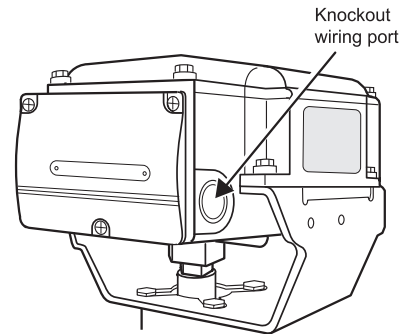

Figure 8. Knockout hole for wiring port

- Correctly connect the wiring to the terminals with M3.5 screws, referring to the wiring terminal diagrams shown in Figs. 10 to 13 and the wiring examples shown in Fig. 14. (For the wiring of the auxiliary switch or the auxiliary potentiometer, refer to Fig. 15.)
- When the ACTIVAL is used in a high-humidity environment or outdoors, use a water-proof connector.

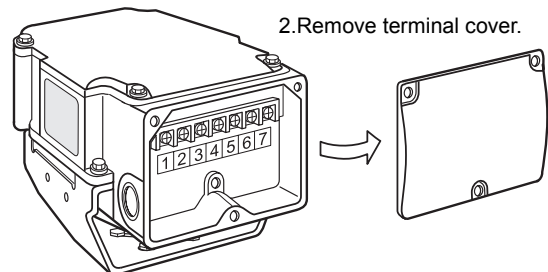
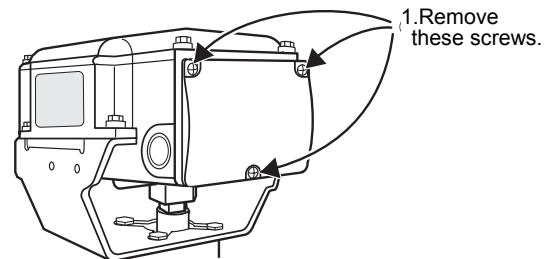
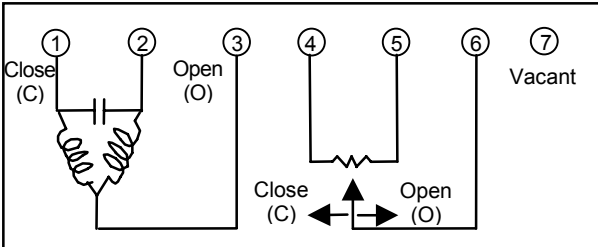

Figure 9. Terminal cover removal
Unscrew the three screws (M4 × 10) to remove the terminal cover. (See Fig. 9.)

For splash-proof enclosure...

- 1) Be sure to completely close the terminal cover and the top cover.
- 2) Waterproof the wiring port.
 - For cable connection, use a water-proof connector.
Recommended product:
Seal conector (Part No. 83104346-003)
 - For conduit connection, use a water-proof plica tube or the like to ensure water proofing.

Wiring Terminals



Model VY5112J00XX

Figure 10. Wiring terminal diagram
Model VY5112J00XX:
(Nominal 135 Ω feedback potentiometer type)

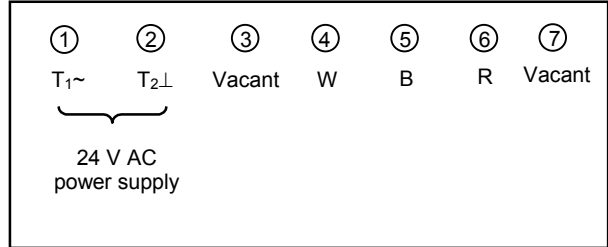

Model VY5122J00XX

Figure 11. Wiring terminal diagram
Model VY5122J00XX:
(Nominal 135 Ω resistance input type)

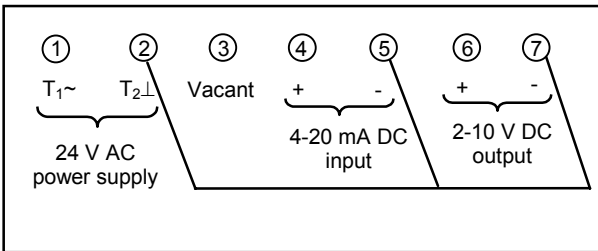

Model VY5132J00XX

Note: The terminals 2, 5 and 7 are connected inside of the actuator.

Figure 12. Wiring terminal diagram
Model VY5132J00XX:
(4-20 mA DC input with 2-10 V DC output type)

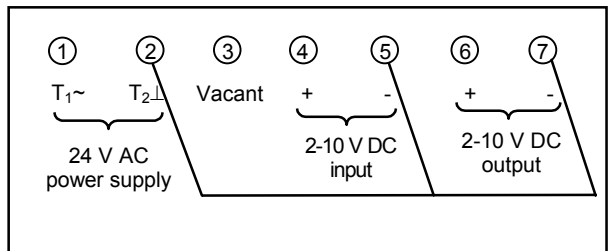

Model VY5142J00XX

Note: The terminals 2, 5 and 7 are connected inside of the actuator.

Figure 13. Wiring terminal diagram
Model VY5142J00XX:
(2-10 V DC input with 2-10 V DC output type)

Wiring Connection Examples: Connection to Yamatake's Controllers

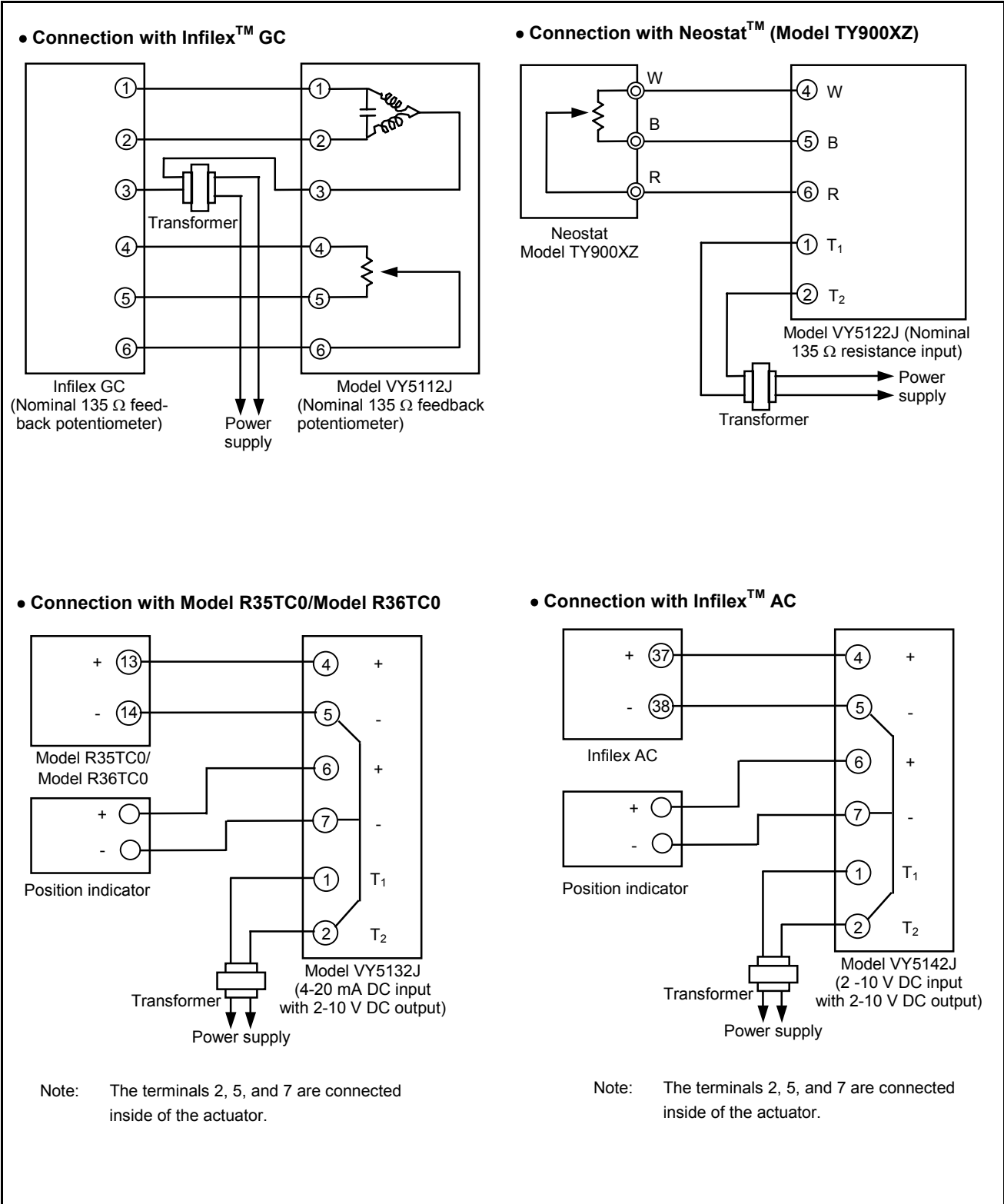
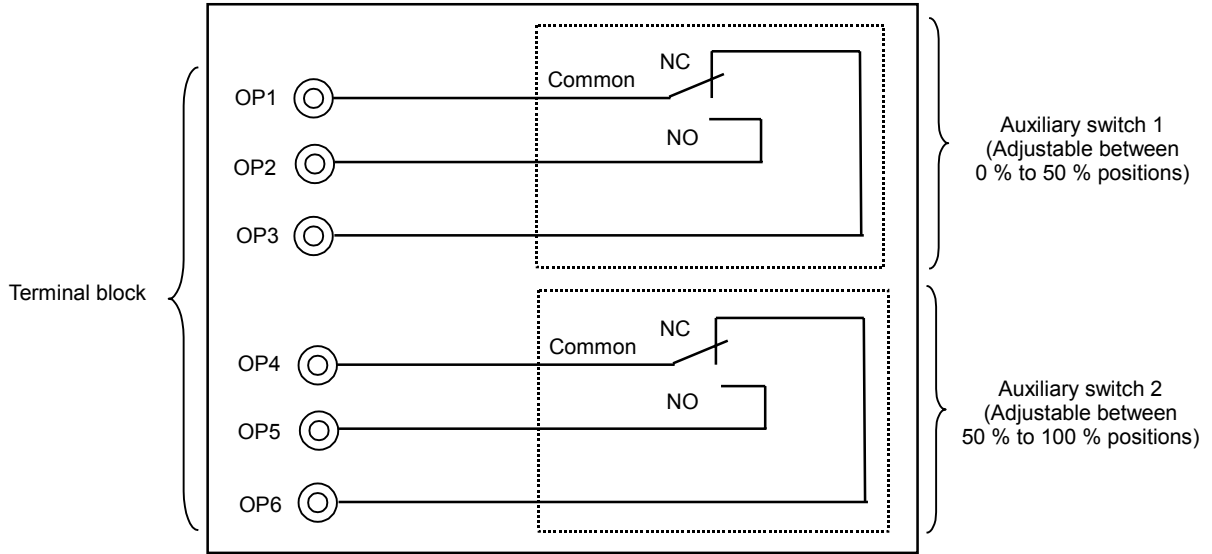

Figure 14. Wiring connection examples

Wiring Connection of Auxiliary Switches / Auxiliary Potentiometer

• Connection of auxiliary switches



Part No. 83161792-001

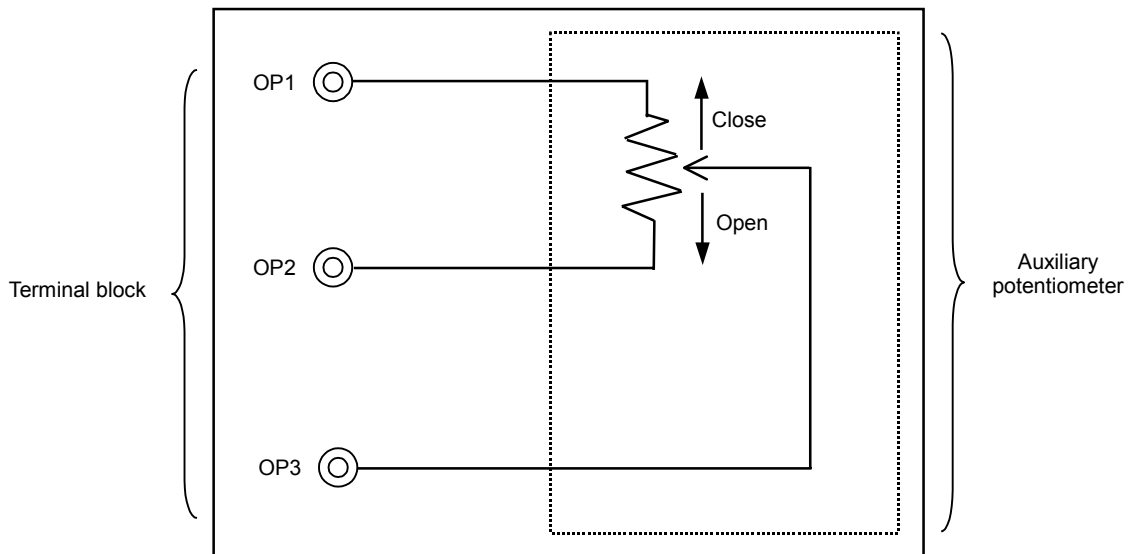

• Connection of auxiliary potentiometer



Part No. 83161793-001

Figure 15. Wiring connection of auxiliary switches/auxiliary potentiometer

Inspection and Maintenance

 CAUTION
 <ul style="list-style-type: none"> Avoid touching the installed ACTIVAL (valve body, yoke, joint). When being used to control hot water, it reaches high temperature and may cause burn injury.

- 1) Inspection
Inspect the ACTIVAL according to Table 1.
Manually open/close the ACTIVAL at least once a month if it is left in inactive state for a long period.
- 2) Maintenance
Visually inspect the fluid leakage of the valve and the actuator operations every six months. If any of the problems described in Table 2 are found, take corresponding actions shown in the table.

Table 1. Inspection items and details

Inspection item	Inspection interval	Inspection detail
Visual inspection	Semiannual	<ul style="list-style-type: none"> Fluid leakage from the gland and the flange face Loosened bolts Valve and actuator damages
Operating status	Semiannual	<ul style="list-style-type: none"> Unstable open/close operation Abnormal noise and vibration
Routine inspection	Any time	<ul style="list-style-type: none"> Fluid leakage to the outside Abnormal noise and vibration Unstable open/close operation Valve hunting

Table 2. Troubleshooting

(If your problem is not solved by the corresponding action, please contact Yamatake near you.)

Problem	Part to check	Action
<ul style="list-style-type: none"> Fluid leaks from the flange face. 	Loosened flange bolts Gasket on the flange face Misaligned piping	Tighten the flange bolts. Replace the gasket. Redo piping.
<ul style="list-style-type: none"> Fluid leaks from the gland part. 	Loosened gland packing	Tighten the gland nut.
<ul style="list-style-type: none"> Fluid leaks from the bonnet. 	Loosened bolts	Tighten the bolts.
<ul style="list-style-type: none"> Valve does not operate smoothly / valve stops halfway / valve does not operate at all. 	Conditions of the power applied and of the input signal applied Loosened terminals Wiring condition / disconnected wires	Check the power supply and the controller connected to. Tighten the terminals. Check the wiring.
<ul style="list-style-type: none"> Fluid leaks to the outside of the valve when the ACTIVAL is in fully closed position. 	Actuator pointer not pointing to fully closed position	Fully close the ACTIVAL.
<ul style="list-style-type: none"> The valve vibrates or produces an abnormal noise. 	Primary pressure condition Differential pressure condition	Adjust the mounting position and installation location.
<ul style="list-style-type: none"> The auxiliary switch does not operate. 	Auxiliary switch (cam switch) condition Loosened terminals Wiring condition / disconnected wires	Redo the cam switch setting. Tighten the terminals. Check the wiring.
<ul style="list-style-type: none"> The auxiliary potentiometer does not operate. 	Condition of resistance Loosened terminals Wiring condition / disconnected wires	Check the resistance value (1 kΩ). Tighten the terminals. Check the wiring.
<ul style="list-style-type: none"> Valve hunting occurs. 	Secondary pressure condition Differential pressure condition	Adjust the mounting position and installation location. Correct the control parameter setting of controller.

Specifications are subject to change without notice.

YAMATAKE

Yamatake Corporation
Building Systems Company

Tamachi Kiyota Building
4-3-4, Shibaura
Minato-ku, Tokyo 108-0023
JAPAN
<http://www.yamatake.com>

Rev. 1.0 Jun. 2005
(J: AI-6465 Rev. 1.0)

AB-6465 0.5H-H (W00)