

Pressure Transmitter PY7100A

General

PY7100A pressure transmitter is a small pressure transmitter using a semiconductor strain gauge. It detects the pressure of chilled/hot water, brine, lubricating oil, steam, air, and other fluids, and converts measured values into 4 to 20 mA DC electric signals for the purpose of measuring and controlling the pressure.

Features

- A small and highly precise pressure transmitter using a semiconductor strain gauge.
- Pressure can be detected stably with an electrical damping function.
- This instrument can detect the pressure of brine, lubricating oil, air, steam, and other fluids as well as chilled/hot water.
- Its wetted parts with measuring fluids are made of stainless steel to ensure the corrosion resistance and a long life.



Dimensions

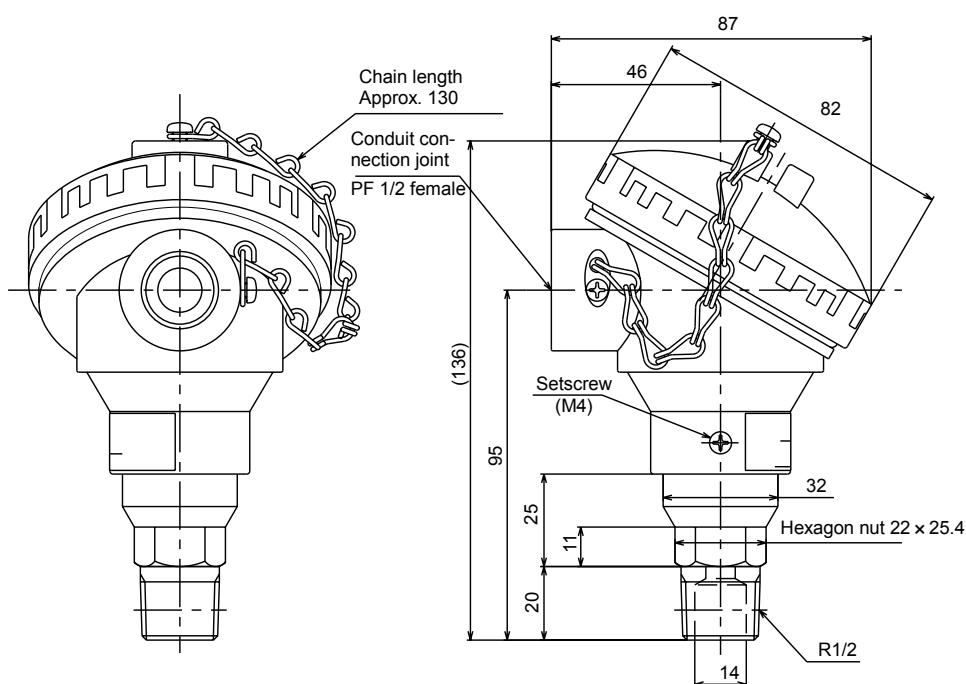

Fig.1 Dimensions (mm)

Specifications

Model numbers, detecting range, allowable pressure resistance

Model No.	Detecting range	Allowable pressure resistance
PY7100A2000	0 to 0.5 MPa	1MPa
PY7100A2008	0 to 1.0 MPa	2MPa
PY7100A2016	0 to 2.0 MPa	4MPa

(The allowable pressure resistance means the pressure limit where the reproducibility is maintainable electrically).

Specifications

Item	Specification
Detection System	Semiconductor strain gauge system
Measuring Object	Detection of pressure of chilled/hot water, lubricating oil, brine, steam, air, and other fluids
Working Temperature range	-20 to 70°C (Non-condensing)
Output Signal	4 to 20 mA DC Linear character output Load resistance 500 or less
Damping Adjustment	Time constant setting range 0.5 to 10 sec. (Approx. 0.5 sec. at the delivery time)
Detection Accuracy	±0.5% FS including the linearity and hysteresis
Influence of Ambient Temperature Fluctuation	±0.05% FS/°C

Item	Specification
Influence of Power Voltage Fluctuation	±0.05% FS/V
Supply Power	24V DC ±10 %
Power Consumption	Approx. 0.5 VA
Zero and Span Adjusting Range	Zero 10% FS Span 20% FS
Dielectric Strength	300V AC, 1 min
Connecting System	R1/2 (male screw)
Case Structure	Drip-proof type (JIS C0920)
Working Ambient Conditions	-20 to 70°C, 5 to 95% RH (Non-condensing) Indoor mounting type
Vibration Resistance	4.9m/s ² (16 to 100Hz)
Ambient Storage Conditions	-30 to 70°C, 5 to 95% RH (Non-condensing)
Weight	Approx. 450 g
Material and Surface Coating Color	Case, cover: Aluminum diecast, silver Wetted parts: Stainless steel
Order Separately	Siphon tube with cocks (Part No. FP10-T01) 24V DC power supply unit (Model QY7000C1000/2000)







Safety Instructions

Please read instructions carefully and use the product properly. Please keep this instruction on hand for reference at any time.

Usage Restrictions

This product is targeted for general air conditioning. Do not use this product in a situation where human life may be affected. If this product is used in clean rooms or places where reliability or control accuracy is particularly required, please contact Yamatake's sales representatives. Yamatake Building Systems Co., Ltd. bears no responsibility for any benefit, or lack of benefit, derived from the operation by the customer.

CAUTION

-  Installer must be a trained, experienced service technician.
-  Check the ratings given in this instruction to prevent equipment damage.
-  Check the environment given in this instruction to prevent equipment damage.
-  All wiring must conform to local codes and ordinances.
-  Disconnect the power supply before beginning wiring to prevent equipment damage.
-  Use crimp contacts with insulation jackets for wire terminals.
-  Do not dissolve this product except for removing the cover during wiring to prevent equipment damage.

Installation

Mounting Place

IMPORTANT

- Mount this transmitter at an indoor place where the ambient temperature is -20°C to 70°C and the humidity is 95% RH or less. (Non condensing. Measuring objects shall be free of being frozen.)
- Keep a space enough for maintenance and adjustment around the instrument.

Installation Procedure

- 1) Be careful not to drop or shock the instrument during transportation, unpacking, and installation.
- 2) Make sure that the model number is as instructed before mounting the instrument.
- 3) Connect the instrument to its piping together with the pressure gauge as shown in Fig. 2.
- 4) Use the siphon for detecting the steam pressure.
- 5) Use the siphon for detecting low temperature liquid (chilled water brine). It prevents sensing part to be broken by dew.
- 6) Mount stop valves for maintenance without fail.
- 7) Mount the instrument to minimize vibrations as much as possible.
- 8) Mount the instrument at $\pm 90^{\circ}$ from the vertical place. Mount it vertically by using the siphon when a steam pipe is used.

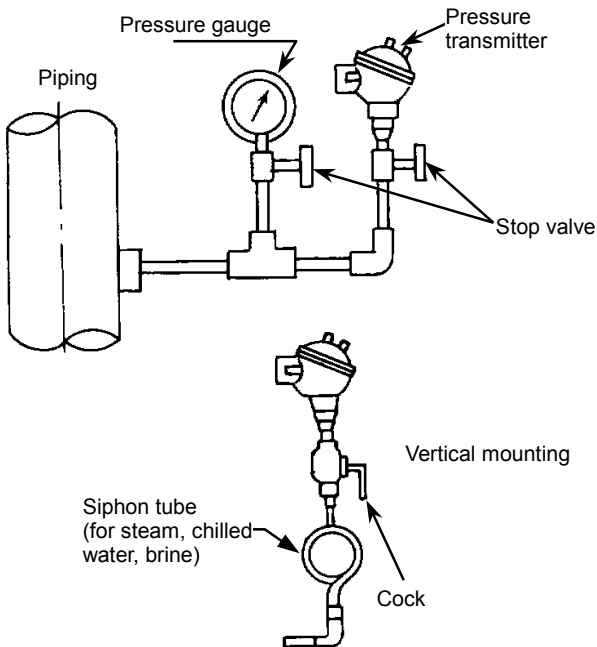

Fig.2 Mounting Method

Installation

Prepare a pressure outlet on the piping, and mount stop valves and R1/2 female screws as shown in Fig. 3. Screw in the pressure transmitter unit next.

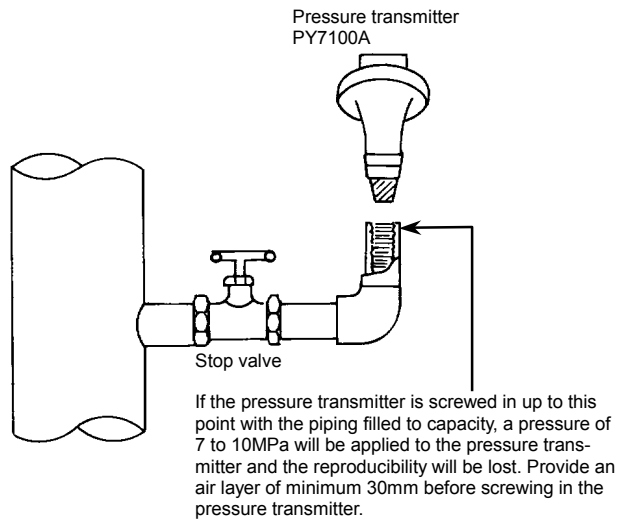

Fig.3 Notes on installation

CAUTION



When the pressure transmitter is installed directly on the piping of low temperature liquid such as chilled water or brine, condensation may occur on the sensor and equipment damage may result. Use a siphon to prevent condensation.

Wiring

IMPORTANT

- For wiring, use an indoor vinyl cable (thicker than IV 1.25mm²)
- Use a shielded cable, if the instrument is presumable to be affected by noises and other interferences through the wiring route. Connect the instrument to the ground on the receiving instrument side.
- For the wiring method, refer to Fig. 4.
- The output (-) side is grounded.

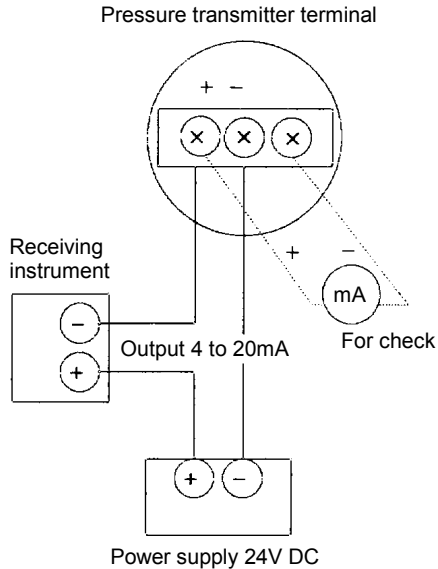

Fig.4 Wiring Diagram

Adjustment

IMPORTANT

- This transmitter has been precisely adjusted before the delivery from the factory, so that the output signals are 4 to 20 mA within the detection range.
- No adjustment is required for normal uses. Adjust the instrument by using a pressure pump and a precision pressure gauge, if you change the relation between the detection range and output signals, or if you set the relation precisely.
- Output signals can be checked across the (+) terminal and terminal CHECK by using an ammeter of 10 or less. (See Fig. 3)

1) Zero Adjustment

Disconnect the instrument from piping before starting zero adjustment. Open the pressure receiving part to the open air, and adjust the ZERO control knob (Z) so that the output signal becomes 4mA.

The output signal increases when turning this control knob clockwise. (The adjustable range is 10% FS.)

2) Span Adjustment

Disconnect the instrument from piping, and apply the high-limit pressure of the detection range by using a

pressure pump. Adjust the SPAN control knob (S) under this condition so that the output signal becomes 20mA. The output signal increases when turning this control knob clockwise. (The span adjustable range is 20% FS.)

3) Damping Adjustment

Adjust the damping by using the DAMPING control knob (D) under the mounting condition of the instrument to the piping, if output signals pulsate. The output pulsation decreases and the response becomes slow when turning this control knob clockwise.

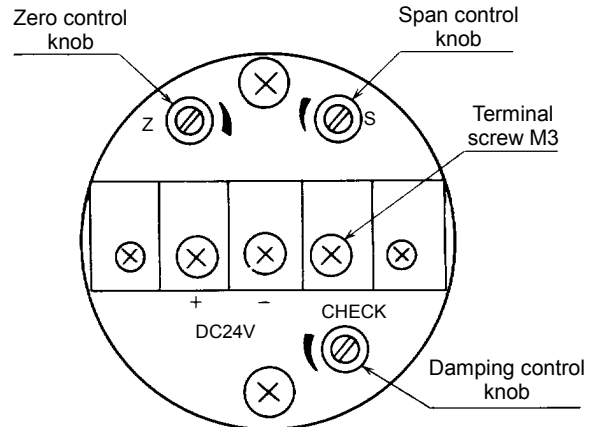

Fig.5 Interior of Terminal Box

Maintenance

No daily maintenance is required, in particular. Check if the transmitter piping mounting joints are free of leak, and the output signals don't pulsate once every year at least.

Dimensions of Siphon Tube with Cocks (option)

Name	Siphon tube with cocks
Part No.	FP10-T01
Allowable pressure resistance	2.0 MPa
Allowable temperature	200°C or less

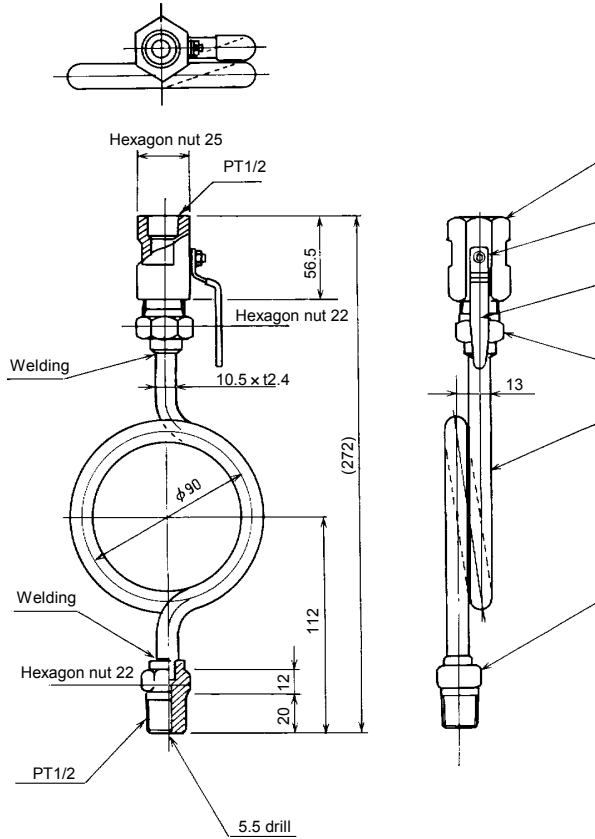

NO.	Name	Material
6	Nut	SUS304
5	Handle	SUS430 (covered with plastics)
4	Body	SCS14
3	Joint	SUS316
2	Pipe	SUS316
1	Joint	SUS316

Specifications are subject to change without notice.

YAMATAKE

Yamatake Corporation
Building Systems Company
International Business Headquarters

Totate International Building
1-12-19, Shibuya
Shibuya-Ku, Tokyo, 150-8316
URL:<http://www.yamatake.com>

First printing Nov. 2000

Printed in Japan. AB-6040 3H-H (W)